

Design and Calibration of A E-Field Probe for Multi Cellular Technology: 2G, 3G and 4G

Reza Bahri* 

Iran Telecommunication Research Center (ITRC),
Tehran, Iran
Reza.bahri@itrc.ac.ir

Ahmad Reza Skandari 

East Tehran Branch, Islamic Azad University,
Tehran, Iran
ar_eskandary@yahoo.com

Seyed Hashem Maddah Hosseini 

Iran Telecommunication Research Center (ITRC),
Tehran, Iran
maddah@itrc.ac.ir

Masoud Arezoumand 

Iran Telecommunication Research Center (ITRC),
Tehran, Iran
arezoomand@gmail.com

Received: 5 September 2022 – Revised: 7 November 2022 - Accepted: 31 February 2023

Abstract—In this paper, a probe for measuring radio-frequency electric fields in the environment is designed and presented. These electric fields consist of multi cellular technology (2G, 3G and 4G), including four bands: GSM900, GSM1800, 3G2100 and LTE2600. This device, called the MCT electric probe, is realized by three orthogonal antennas, in connection to frequency multiplexer circuits and detectors. The proposed antenna is a 3-D multi-branch monopole antenna, and these orthogonal antennas can receive the electric fields in all directions uniformly and isotropically. The proposed multiplexer can separate the received signals into four narrowband and has the ability to remove out-of-band signals. The detector is able to convert the fields received from the antenna and multiplexer sections to suitable DC voltages for amplifying and digital processing. Finally, the designed MCT electric probe is fabricated and tested. The measurements confirm the proper operation of the probe in terms of dynamic range, accuracy, sensitivity, and the linearity and isotropicity of the received electric fields.

Keywords: Electric probe, Cellular Network, multiplexer, detector

Article type: Research Article



© The Author(s).

Publisher: ICT Research Institute

I. INTRODUCTION

With the rapid development of communication technologies in recent years, the demand for portable communication devices is increasing rapidly. Portable devices, such as mobile phones, are being extensively researched [1]-[8]. As devices used in close proximity to the human body become commonplace in modern

life, concerns about the health risks from the associated electromagnetic fields have increased. To evaluate the exposed E-fields, an effective device such as electric fields probe is needed [6]-[8].

The E-field probes have been studied by many researchers [1]-[12]. The probes reported in recent research are able to measure the electric fields in

* Corresponding Author

broadband frequency bands, usually from frequencies below 1 GHz and sometimes up to 20 GHz [6]. A broadband electric field probe consists of an electrically short dipole antenna connected to a diode detector and high impedance transmission line to measure the incident EM field [9], [11]. So far, little research has been studied on the E-field probes in narrow band including the GSM frequency bands.

In this paper, the E-field probe that is operated at the frequency bands (including: GSM900, GSM1800, 3G and LTE) is designed. The proposed design, shown in Fig.1, consists of three basic components, which are antenna, frequency multiplexer, and detector. The antenna receives the electric fields in the GSM frequency bands. The multiplexer separates the GSM frequency bands into four bands as: GSM900 (790~960 MHz), GSM1800 (1710~1880 MHz), 3G2100 (1920~2170 MHz), and LTE2600 (2500~2690 MHz). Finally, the separated signals are detected by diode detector, and then these DC signals are amplified and sent to the digital unit for processing. In the following, the design and implementation of these components will be realized. At last, the designed MCT electric probe is fabricated and tested. The measurements confirm the proper operation of the probe in terms of dynamic range, accuracy, sensitivity, and the linearity and isotropicity of the received electric fields.

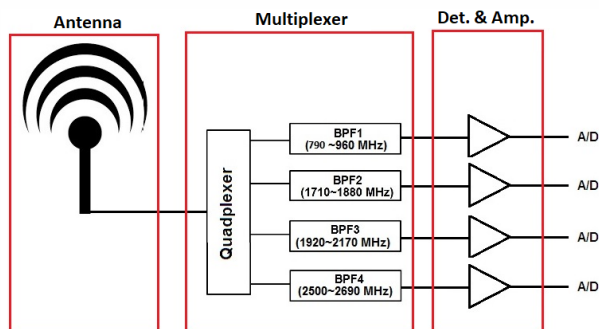

Figure 1. Proposed structure of the MCT probe.

II. DESIGN AND FABRICATION OF ANTENNA

The antenna of the MCT probe must be able to receive four mobile frequency bands (GSM900, GSM1800, 3G2100, LTE2600). Such multi/wide-band antennas with different structures have been researched in the last two decades [13]-[17]. To design this antenna, a 3-D multi-branch monopole antenna has been proposed and designed. The photograph of the proposed antenna is shown in Fig. 2.

Fig. 3 shows the dimensions of the fabricated antenna. As shown in this figure, a single bent monopole has been placed in the center of the structure and four branches are located in the around. The bent monopole antenna should operate for the lower band and the branches should operate with the other high bands. By using HFSS software, design and simulation of the proposed antenna have been done (Fig. 4). The

monopole length, and height, spacing and length of the branches have been calculated and optimized using the HFSS and as shown in Fig. 3.

The antenna is attached to the top-center of a metal box ($60 \times 60 \times 25 \text{ mm}^3$) and is covered by radome, to simulate the probe antenna, as shown in Fig. 5. The material of the designed 3D printed radome is polyurethane foams that offer an effective solution for cost effective and both versatile and robust. Easily optimized material allows for high performance with low dielectric interference

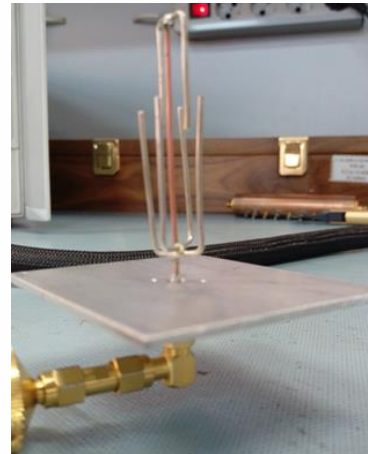

Figure 2. Fabricated multi-band monopole antenna.

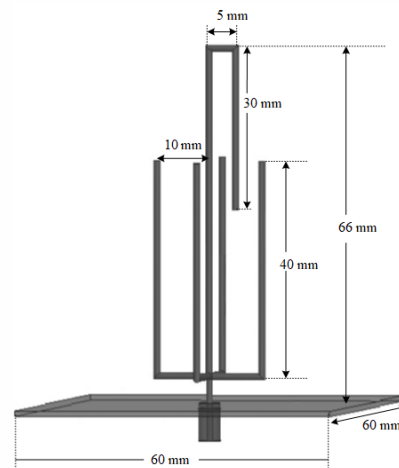

Figure 3. The proposed multi-band antenna with dimensions.



Figure 4. Simulation of the proposed antenna by using HFSS.

The simulated and measured return loss of the antenna is depicted in Fig. 6. As shown in this figure, the impedance bandwidths under -10 dB can cover the GSM standards; GSM900, GSM1800, 3G2100, and LTE2600. Fig. 7 plots the measured radiation patterns at the frequencies 900, 1800, 2100, and 2600 MHz. The radiation patterns for other frequencies are similar to the radiation patterns of the four frequencies shown in Fig. 7. Here, omnidirectional radiations in the plane are observed.

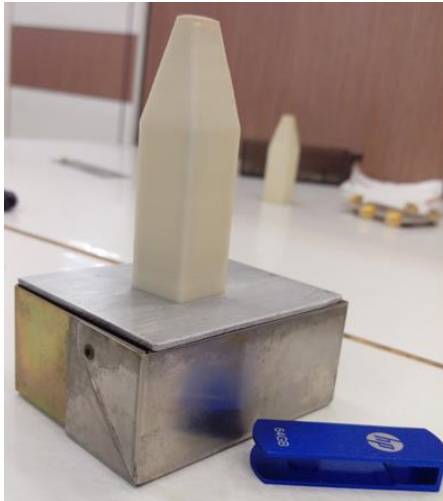

Figure 5. Fabricated antenna with radome.

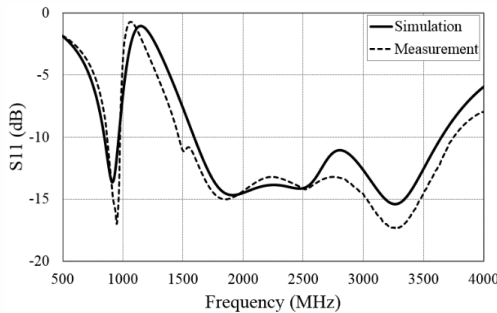

Figure 6. Simulated and measured return loss of the multi-band antenna.

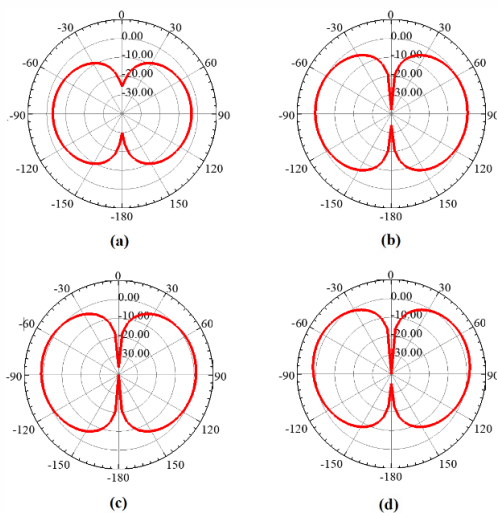

Figure 7. Measured radiation patterns at: (a) 900 MHz, (b) 1800 MHz, (c) 2100 MHz, (d) 2600 MHz for the antenna studied in Fig. 5.

III. DESIGN AND FABRICATION OF FREQUENCY MULTIPLEXER

Multiplexers can separate a wideband signal from common port into several narrowband signals at output ports. Many approaches have been investigated to achieve high performance of the multiplexers for practical applications, such as low passband loss in each channel, high isolation between channels and overall compact sizes. To this end, there are some good literatures published [18-22].

In Fig.8, a general structure of the multiplexer is shown. This structure consists of four separate filters and these filters are connected to each other so that one of the ports should be matched at its center frequency and the other ports should be look opened. The challenge of this structure is realization of the small dimensions.

In the following, a quadruplexer with compact size, high isolation, and flexible passband frequencies are presented. Since there are no extra matching networks, the proposed quadruplexer is compact. Design method of the quadruplexer is described in [20].

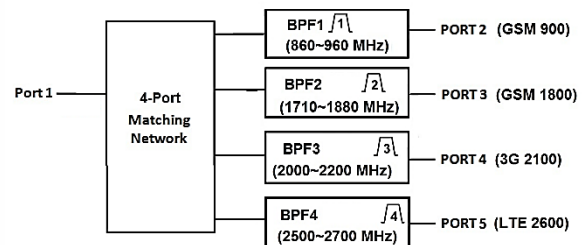

Figure 8. The general structure of the frequency multiplexer

A. Unit cell design

Basically, there are four unit cells in the proposed quadruplexer, and each unit cell is a bandpass filter as shown in Fig. 9. The unit cell consists of a distributed coupling feeding line (Input), a pair of resonators in open-circuit square loops, and an output feeding line. Design method of this cell is reported in [17]. Here, circuits are simulated by HFSS software on a RO6010 substrate with a relative dielectric constant of 10.5 and a thickness of 1.27mm. The dimensions of the unit cell for the BPF2 (1710~1880 MHz) have been calculated and optimized using the HFSS and reported in Table 1. The simulated results are shown in Fig. 10.

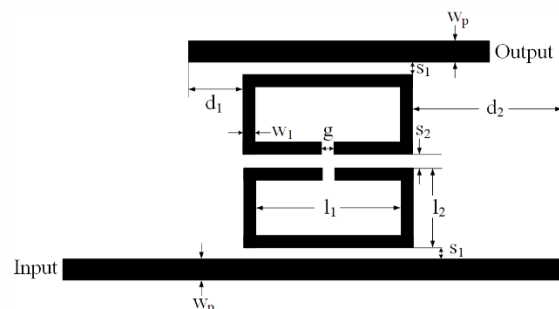

Figure 9. Proposed unit cell of the quadruplexes

TABLE I. DIMENSIONS OF THE UNIT CELL

Parameter	l_1	l_2	S_1	S_2	g	w_1	d_1	d_2
Dimension	10.2	3.4	0.1	0.6	0.1	0.4	14.4	11

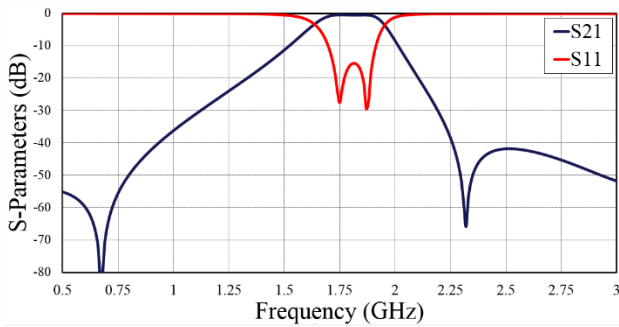

Figure 10. Simulated S-parameters for BPF2

B. Quadruplexer design

Here, based on the design process in [20], a quadruplexer with high isolation is presented. This structure is shown in Fig. 11. The design procedure for the quadruplexer is two steps: the first, design four single-band two-pole bandpass filters with harmonic suppression, and the second, combine the four bandpass filters into a quadruplexer by sharing the input feeding line.

The full-wave simulation of the quadruplexer is carried out by HFSS. The dimensions of the circuit have been calculated and optimized, and reported in table 2. To reduce the radiation effects of this circuit on adjacent circuits, stripline technology is used in the fabrication of the quadruplexer. The circuit is fabricated on a 1.27-mm RO6010 substrate. The photograph of the fabricated circuit is depicted in Fig. 12. The results of the simulation and measurement of S parameters are shown in Fig. 13. Based on the results in Fig. 13, it can be mentioned that the proposed multiplexer has the potential to be applied for the GSM probe.

It should be considered that the differences between the results obtained in the simulations and measurements are caused tolerance in fabrication, variation in the electromagnetic properties of substrate (the exact value of the dielectric permittivity was not measured for the utilized material).

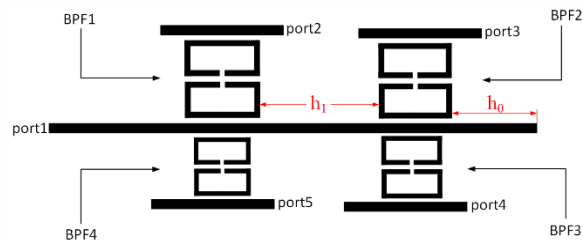
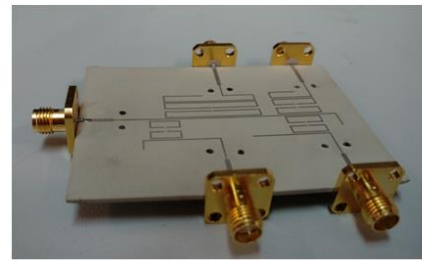

Figure 11. Structure of the proposed quadruplexes

TABLE II. DIMENSIONS OF THE QUADRUPLER

Parameter	l_1	l_2	S_1	S_2	g	w_1	d_1
BPF1	29.1	2.4	0.15	0.45	0.6	0.4	19
BPF2	12.6	2.4	0.45	0.8	0.7	0.4	8.2
BPF3	10.2	2.4	0.22	0.8	0.2	0.4	9.2
BPF4	8.1	2.4	0.25	1	0.4	0.4	8.2



(a)

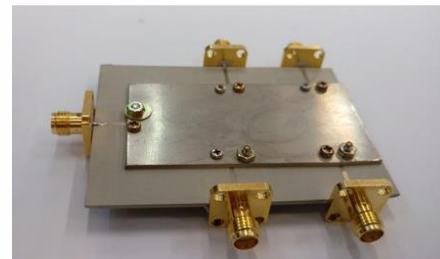

(b)

Figure 12. Fabricated multiplexer in (a) microstrip, (b) strip line structure

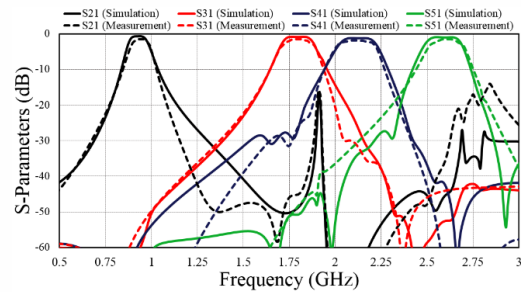

(a)

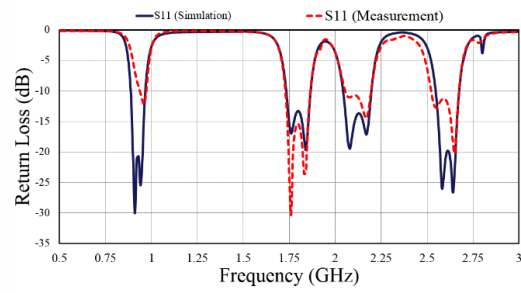

(b)

Figure 13. Simulated and measured S parameters of the quadruplexes

IV. DETECTOR DESIGN

After receiving the signal by the antenna and filtering it by the multiplexer in the four frequency bands, it is necessary to have a suitable detector to convert the RF signal into a DC signal. The diode selected for detection in this design is MA4E2054 made by MACOM company. The MA4E2054 series are low barrier Schottky diodes, and the main advantages of them are: high detector sensitivity, low capacitance and to make the frequency response of the

probe very flat [23].

The diode with a low-pass filter and side circuits for detection are depicted in Fig. 14. The dynamic range of this circuit is about 60 dB, and it has the ability to detect minimum power of -55 dBm.

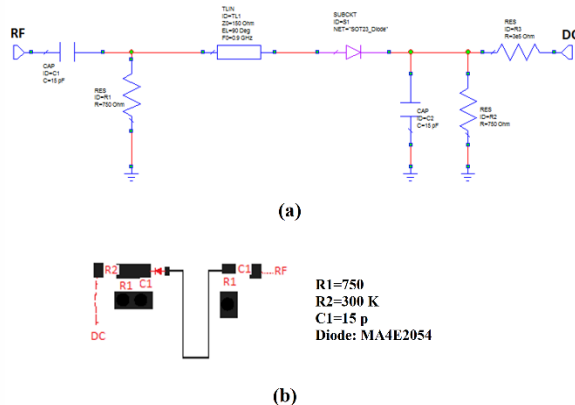

Figure 14. Detector circuit for the MCT probe: (a) schematic, (b) layout.

V. RESULTS AND MEASUREMENTS

After designing and verifying the performance of three components of the MCT probe, it should be possible to connect three components together in the compact space. The final layout of the antenna, multiplexer and detector is shown in Figure 15. In this figure, the multiplexer with the detector circuit is printed on a square board with dimensions 60x60 mm². The antenna is perpendicular to the board, located back of the board and soldered at the RF point. Based on this, a set of MCT probe is made and tested.

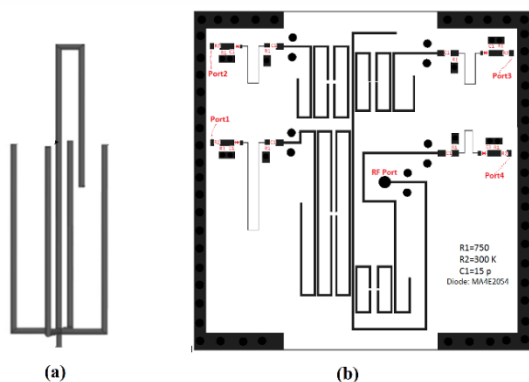

Figure 15. Layout of the (a) antenna, and (b) multiplexer & detector.

The fabricated circuit has the ability to receive the electromagnetic radiation only in the direction of one axis. To measure the total electric field, the electric fields must be measured in three orthogonal directions. In fact, probe isotropy is achieved by the mutually orthogonal configuration of three antennas on three axes direction: X, Y, and Z. Therefore, the GSM probe consists of three orthogonal antennas, which are shown in Figure 16. and each has its own multiplexer and detector circuits. This set is housed inside a cube enclosure.

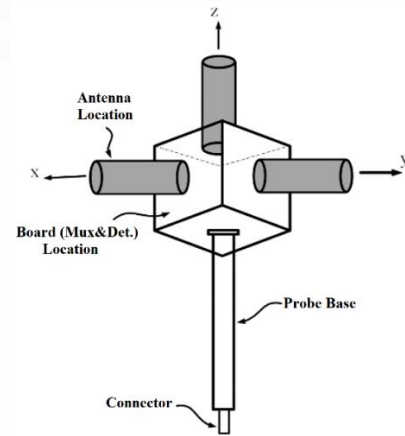

Figure 16. A 3D view of MCT probe

Finally, the designed GSM probe is fabricated and tested. Photograph of the fabricated GSM probe is shown in Fig. 17. The measurements and calibration of this probe are done in an anechoic chamber.

One of the most important tests is to measure the linearity of the probe and calculate its dynamic range. To measure the linearity of the probe, the input power is changed linearly using the signal generator. As input power is increased, the probe receives the transmitted signal in the anechoic chamber and the detected signal is transformed into a voltage. Fig. 18 shows measurement result of linearity characteristic of the probe in the frequencies of: 900, 1800, 2100, and 2600 MHz.. As the input power increases, the output voltage value of the probe also increases linearly. The proposed probe can measure the E-field from 0.1 V/m to 65 V/m at the GSM frequency bands, and so dynamic range of 56 dB is considerable for this probe.

The measured radiation pattern of the probe is also measured in the anechoic chamber. As the input power is fixed, the designed probe is rotated in the anechoic chamber and measured output E-fields. The measurement results of isotropic deviation have been shown in table 3. Also, in the table 3, specifications and the rest measurement results of the proposed probe have been reported. The measurements confirm the proper operation of the probe in terms of dynamic range, accuracy, sensitivity, and the linearity and isotropicity of the received electric fields.

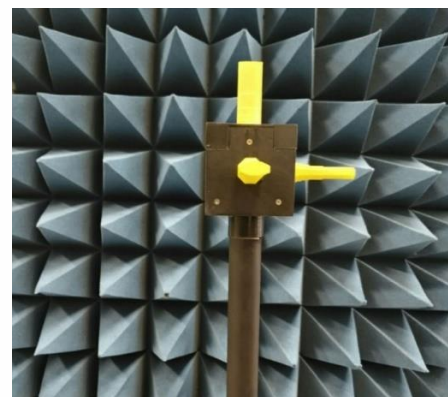

Figure 17. Fabricated MCT probe in the anechoic chamber of ITRC Antenna Lab

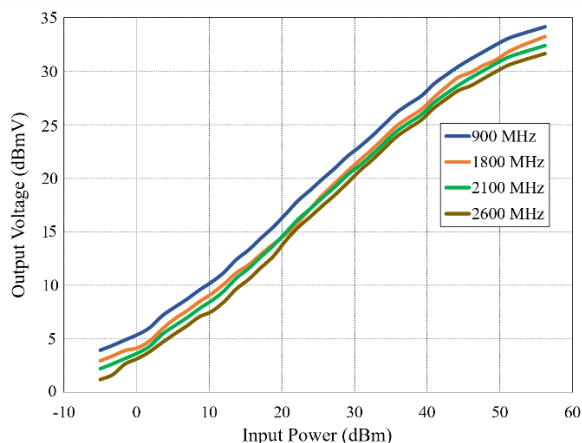

Figure 18. Measurement results: Linearity

TABLE III. SPECIFICATIONS AND THE MEASUREMENT RESULTS OF THE PROPOSED PROBE

Frequency Bands	GSM900
	GSM1800
	3G2100
	LTE2600
Measurement Range	0.1 - 65 V/m
Dynamic Range	56 dB
Sensitivity	0.1 V/m
Resolution	0.5 dB
Frequency Response	± 3.3 dB
Linearity	± 1 dB
Isotropic Deviation	±1.7 dB
Operating Temperature	10C to +40°C
Temp. Response	± 0.6 dB @ 10°- 40°C
Dimensions	30.12*12 cm
Weight	350g

VI. CONCLUSION

In this paper, a GSM probe has been designed and fabricated to measure the electric fields in the GSM frequency bands, including: GSM900, GSM1800, 3G2100 and 4G2600. The electric fields have been linearly measured in the range of 0.1 to 65 V/m, which confirms the dynamic range of about 56dB. The fabricated GSM probe characteristics such as linearity, sensitivity and isotropic deviation accuracy have been presented in this paper. The fabricated probe can be used in the personal exposure meter to evaluation of exposed an electric field from the electronic devices.

ACKNOWLEDGMENT

This work is supported by Iran Telecommunication Research Centre (ITRC) and Communication Regulatory Authority (CRA).

REFERENCES

- [1] Shan Xue, Shaodong Yang, Weiheng Shao, Xinxin Tian, Duolong Wu, "Electric Field Probe De-Embedding Calibration Based on Through and Line Standards", *IEEE Sensors Journal*, vol.23, no.7, pp.6999-7007, 2023.
- [2] Y. Xiong, X. Yang, S. Wan and Y. Zhou, "Discussion on Computing Isotropy of E-field Probe," 2022 Asia-Pacific

- International Symposium on Electromagnetic Compatibility (APEMC), Beijing, China, 2022, pp. 318-320, doi: 10.1109/APEMC53576.2022.9888413.
- [3] Z. Mao, C. Zhang, Z. Wang, L. Duan, J. Gu and W. Tang, "A Broad-Band PCB Isotropic Electric-Field Probe with Resistance Loaded Dipoles," 2022 IEEE Conference on Antenna Measurements and Applications (CAMA), Guangzhou, China, 2022, pp. 1-3, doi: 10.1109/CAMA56352.2022.10002567.
- [4] S. i. Kwak, B. C. Kim, and H. D. Choi, "Analysis of isotropic deviation of the electric-fields probe in the personal exposure measurement meter," *ICTC 2012*, 235-237, Oct. 2012.
- [5] S. i. Kwak, J. H. Kwon and Y. J. Yoon, "Experimental Results of an E-Field Probe Using Variable Resistors to Improve Performance," in *IEEE Antennas and Wireless Propagation Letters*, vol. 15, pp. 1369-1372, 2016.
- [6] S. I. Kwak, J. H. Kwon and Y. J. Yoon, "Design of the E-field probe for mobile communication bands in the personal exposure meter," *The 18th IEEE International Symposium on Consumer Electronics (ISCE 2014)*, Jeju, Korea (South), 2014, pp. 1-2.
- [7] S. I. Kwak, J. H. Kwon and Y. J. Yoon, "Design of the E-field probe with variable resistors," 2014 International Symposium on Antennas and Propagation Conference Proceedings, Kaohsiung, Taiwan, 2014, pp. 353-354.
- [8] S. I. Kwak, B. C. Kim, H. D. Choi, and Y.J. Yoon, "Design of the electric-fields probe in the personal exposure meter," *PIERS Proceedings*, Stockholm, Sweden, Aug. 12-15, 2013.
- [9] M. Kanda, "Standard probes for electromagnetic field measurements," in *IEEE Transactions on Antennas and Propagation*, vol. 41, no. 10, pp. 1349-1364, Oct. 1993.
- [10] J. Qin, Q. Zhu, W. Zhou, L. Xue and X. Feng, "Uncertainty Evaluation and Calibration of Electric Field Probe Under GTEM Cell," *2019 International Conference on Robots & Intelligent System (ICRIS)*, 2019, pp. 474-478.
- [11] Guo Hongfu, Fu Mi and Tang Jinfeng, "Analysis of UWB electric-field probe with different materials," *Proceedings of the 9th International Symposium on Antennas, Propagation and EM Theory*, 2010, pp. 1147-1150.
- [12] A. Sarolic and B. Modlic, "Measurement of Electric Field Probe Response to Modulated Signals Using Waveguide Setup," in *IEEE Antennas and Wireless Propagation Letters*, vol. 9, pp. 1041-1044, 2010.
- [13] M. Arrawatia, M. S. Baghini and G. Kumar, "Broadband omnidirectional antenna for GSM900, GSM1800, 3G, 4G and Wi-Fi applications," 2017 IEEE International Symposium on Antennas and Propagation & USNC/URSI National Radio Science Meeting, San Diego, CA, USA, 2017, pp. 329-330.
- [14] R.A. Sadeghzadeh, M.A. Honarvar, A.R. Eskandari, "Coplanar-fed UWB elliptical patch antenna with notched band characteristics," *Progress In Electromagnetics Research Symposium Proceedings*, Xi'an, China, March 22–26, 2010.
- [15] S. I. Al-Mously and M. M. Abousetta, "A Novel Multi-Wideband Antenna Using a 3-D Multi-Branch Monopole Structure for GSM-Family and Other Cellular Applications," *2007 8th International Conference on Telecommunications in Modern Satellite, Cable and Broadcasting Services*, 2007, pp. 577-580
- [16] L. Zhao, Z. Chen and J. Wang, "A Wideband Dual-Polarized Omnidirectional Antenna for 5G/WLAN," in *IEEE Access*, vol. 7, pp. 14266-14272, 2019.
- [17] J. Xie, Y. Gao and C. Y. Xia, "A design of three-band monopole antenna applied to 4G/5G," 2020 International Conference on Computer Communication and Network Security (CCNS), Xi'an, China, 2020, pp. 99-103.
- [18] W. Tu and K. Hsu, "Design of Sext-Band Bandpass Filter and Sextaplexer Using Semilumped Resonators for System in a Package," in *IEEE Transactions on Components, Packaging and Manufacturing Technology*, vol. 5, no. 2, pp. 265-273, Feb. 2015.
- [19] J. Z. Chen, N. Wang, K. Deng, and S. Yang, "Design of Compact Quadruplexer Based on Defected Stepped Impedance Resonators", *Progress In Electromagnetics Research*, Vol. 119, pp. 19-33, 2011.
- [20] S. Zeng, J. Wu and W. Tu, "Compact and High-Isolation Quadruplexer Using Distributed Coupling Technique," in *IEEE Microwave and Wireless Components Letters*, vol. 21, no. 4, pp. 197-199, April 2011.

- [21] S. Lo, K. Hsu and W. Tu, "Compact and high-isolation microstrip quadruplexer," *2013 Asia-Pacific Microwave Conference Proceedings (APMC)*, 2013, pp. 966-968.
- [22] Hong-Wei Deng, Yong-Jiu Zhao, Yong Fu, Ji Ding, and Xiao-Jun Zhou, "Compact and High Isolation Microstrip Diplexer for Broadband and WLAN Application", *Progress In Electromagnetics Research*, Vol. 133, pp. 555-570, 2013.
- [23] <https://cdn.macom.com/datasheets/MA4E2054%20Series.pdf>.



Reza Bahri received B.Sc. degree in Electrical Engineering from Tehran University, Tehran, Iran, in 2002, and M.Sc. degree in Communication Engineering from Amirkabir University of Technology, Tehran Iran, in 2009, and Ph.D. candidate in Communication Engineering in Amirkabir University of Technology, Tehran, Iran. His main research interests are RF, Microwave, MM-wave, THz circuits and systems, Linear and Nonlinear Modeling of Circuits and Devices, Wireless Communications Transceivers, Electromagnetic and Microwave Measurement. He is currently Faculty Member and Head of Radio Communication Research Group in Iran Telecommunication Research Center (ITRC).



Ahmadreza Eskandari received B.Sc. and M.Sc. degrees in Electrical Engineering from Sharif University of Technology, Tehran, Iran, in 2002 and 2005, respectively, and the Ph.D. degree in Electrical Engineering from the Science and Research Branch, Islamic Azad University, Tehran, Iran, in 2012. He is currently an Assistant Professor with the Department of Electrical Engineering, East Tehran Branch, Islamic Azad University, Tehran, Iran. His research interests are Satellite Communication Systems, Inverse Scattering in Electromagnetics, and Design of Antenna and Microwave Components.



Seyed Hashem Maddah Hosseini received the B.Sc. degree in Telecommunication Engineering from the K. N. Toosi University of Technology, Tehran, Iran, in 1991, and the M.Sc. degree in Telecommunication Engineering from Tarbiat Modares University, Tehran, Iran, in 1996. He is specialist in Mobile Communication Systems and ICT Strategic Issues. He has been working in ITRC (Iran Telecommunication Research Center) since 1995 and doing research in the field of Telecommunications.



Masoud Arezoomand received B.Sc. Degree from Ferdowsi University of Mashhad, Mashhad, Iran and M.Sc. degree from Sharif University of Technology, Tehran, Iran, both in Electrical Engineering 1988 and 1991, respectively, He was a Member of Scientific Board of ICT Research Institute of Iran (former ITRC) since 1988 till 2021. Also, he is a lecturer of communication and radio propagation in many universities in Tehran, Iran. He won two first prizes of National Khwarizmi Festival for Design and Implementation of Digital Microwave Radio and a third place of Iran ICT Festival for Design of Field Intensity Measurement System His research interests are Radio Communication Systems, Antenna and propagation, EMC, Electric and Magnetic Field Measurement and Microwave Circuit Design.